

LPG Association Code of Practice  
LPGA COP No 2

# Installation and maintenance of twin 45 kg LPG cylinder systems

November 2019

LPG Association of New Zealand Inc  
PO Box 1776  
Wellington  
New Zealand



## Foreword

The performance of LPG cylinder installations is a critical element in ensuring that gas is supplied to appliances reliably and safely. This Code of Practice (Code) has been compiled with advice and input from across the industry in New Zealand and from international authorities. The Code of Practice captures the latest knowledge and design features gained from operating experience and investigative work conducted by the LPG Association.

The purpose of this Code of Practice is to assist with:

- the selection of suitable equipment and fittings; and
- recommendations on equipment maintenance.

It should be read in conjunction with AS/NZS 5601.1.

It is intended that gas fitters will use this Code as a best practice guide for the installation and maintenance of domestic and commercial LPG installations up to 100 kg capacity.

## Contents

<b>Foreword</b> .....	<b>2</b>
<b>Section 1: Scope, Interpretation, Definitions and General</b> .....	<b>5</b>
1.1 Scope .....	5
1.2 Definitions.....	5
<b>Section 2: Selection Criteria for LPG Cylinders, Pigtails, Changeover Valves and Regulators ...</b>	<b>8</b>
2.1 Cylinders.....	8
2.2 Changeover valves.....	8
2.3 Regulators .....	9
2.4 Condensate trap .....	9
2.5 Non-return valves .....	9
2.6 Excess flow valves.....	9
<b>Section 3: Location of Cylinders</b> .....	<b>10</b>
3.1 General .....	10
3.2 Prohibited locations.....	10
3.3 Cylinders on a verandah .....	10
3.4 Cylinders in an enclosure or recess.....	11
3.5 Cylinders under buildings .....	11
3.6 Requirements for cylinder location .....	12
<b>Section 4: Cylinder Installation</b> .....	<b>14</b>
4.1 Installing cylinders .....	14
4.2 Clearances around cylinders .....	15
4.3 Cylinder safety valve discharge .....	16
4.4 Regulators .....	16

---

4.5	Piping.....	17
4.6	Meters.....	18
4.7	Hazardous area requirements.....	18
4.8	Test points .....	19
<b>Section 5: Maintenance LPG Cylinder Installations up to 100 kg.....</b>		<b>20</b>
5.1	Cylinders.....	20
5.2	Flexible pigtailed manufactured to AS/NZS 1869.....	20
5.3	Changeover valves.....	20
5.4	First-stage regulators.....	20
5.5	Second-stage regulators .....	20
5.6	Condensate traps .....	20

## Section 1: Scope, Interpretation, Definitions and General

### 1.1 Scope

This Code of Practice sets out the requirements for installation and servicing of domestic and commercial twin 45 kg cylinder LPG installations.

### 1.2 Definitions

For the purposes of this Code the following definitions apply:

**Accessible:**

Access can be gained without hazard or undue difficulty for inspection, repairs, testing, maintenance, renewal or operational purposes.

**Automatic changeover regulator:**

Combination valve/first-stage gas pressure regulator fitted to an LPG multiple-cylinder installation that will automatically change over from a cylinder in use to a reserve cylinder at a predetermined pressure. May be included in a one-piece automatic changeover valve assembly comprised of automatic changeover valve, first- and second-stage regulators and may incorporate pressure relief or over pressure shut off capability.

**Breather vent:**

An orifice or opening designed to permit atmospheric pressure to act on the diaphragm of a regulator.

**Condensate:**

The liquid that separates from the LPG down stream of any regulator owing to the reduction in temperature resulting from pressure reduction. It consists of higher hydrocarbons. The amount of condensate/residue is controlled under the LPG Specification AS 5435.

**Condensate trap** (also known as a drip leg or tailpipe):

A device installed in a gas line to trap the condensate liquid.

**Contaminants:**

A term given to a multiple of items that can build up in an LPG installation, this can include specks of rust from the LPG cylinders, installation equipment or extractible phthalates, the plasticiser found in some pigtailed that use a particular rubber inner liner.

**Gasfitting:**

Has the same meaning as in the Plumbers, Gasfitters and Drainlayers Act 2006.

**Gas installation:**

A combination of the following, used or intended to be used, in the supply and utilisation of gas, taken as separate items or as a whole: consumer piping, fittings, components, appliances, flues, sub-meters, apparatus or other devices and associated equipment.

**Gas load:**

The total gas consumption of all downstream appliances.

**Gas meter:**

A device used to measure the volume of gas passing through it.

**Gas pressure regulator:**

A device that automatically regulates the outlet pressure of the gas passing through it to a predetermined value.

**HSW:**

Health and Safety at Work Act 2015.

**HSW HS:**

Health and Safety at Work (Hazardous Substances) Regulations 2017.

**LAB number:**

Number allocated by Worksafe New Zealand when a cylinder is approved.

**Lock-up pressure:**

The maximum pressure in an installation when the regulator has closed and all appliances are shut down.

**Non-return valve:**

A valve designed to operate automatically to prevent reversal flow in a pipe or fitting.

**Phthalates:**

Plasticisers mainly DOP (DiOctyl Phthalates) predominantly found in pigtail inner liners.

**Pigtail:**

A short length of flexible tube or copper pipe completed with end couplings. Used for connecting the cylinder to the manifold or the changeover valve.

**POL fitting (Prest-O-Lite):**

The common name given for a standard union with left hand thread, used for connection to a 45 kg cylinder.

**Pressure:**

As measured above atmospheric pressure, also called gauge pressure.

**Relaxation Time:**

A period of low or no LPG draw-off which allows a cylinder to recover vapour pressure and reach temperature equilibrium.

**Twin cylinder installation:**

A cylinder installation where the cylinders are connected separately to the system. Each cylinder is connected to a changeover valve that can be operated manually or automatically to change over the cylinder supplying LPG to the installation. Connection may be made using flexible rubber or copper pigtails, or pipe fittings.

**WorkSafe:**

WorkSafe New Zealand established by section 5 of the WorkSafe New Zealand Act 2013.

**REFERENCED DOCUMENTS**

HSW HS Regs	Health and Safety at Work (Hazardous Substances) Regulations 2017
AS/NZS 5601.1	Gas Installations
AS/NZS 1596	The storage and handling of LPG
AS/NZS 1869 2012	Hose and hose assemblies for liquefied petroleum gases (LP Gas), natural gas and town gas
UL144	LP- Gas regulators
UL252, AGA 205	Compressed gas regulators
NF M 88-769	1977 Commercial Propane Installations in Movable Containers – Coupling and Automatic Changeover Device – Construction – Operation – Tests

## Section 2: Selection Criteria for LPG Cylinders, Pigtails, Changeover Valves and Regulators

### 2.1 Cylinders

- (a) All cylinders must comply with the requirements of Part 15 (Gases under pressure) of the Health and Safety at Work (Hazardous Substances) Regulations 2017.
- (b) Cylinders filled for use in LPG installations must be stamped with an LAB or LABSP number and a current test date.
- (c) Consideration should be given to ensure that the demand of the appliances to be connected to the system can be supplied by a cylinder.

As a guide on NZ LPG mix, a 45 kg cylinder is capable of supplying a continuous duty cycle of 1 kg/hr or 50 MJ/hr for the duration of the LPG supply.

An instantaneous demand of up to 6 kg/hr or 300 MJ/hr can be supplied for short periods, up to approximately 10 minutes, provided sufficient relaxation time is allowed between each high draw event to equate to 1 kg/hr continuous draw over time.

### 2.2 Changeover valves

- (a) Changeover valves can be manual or automatic and may include a non-return valve on each pigtail connection. The valve must comply with the requirements of WorkSafe New Zealand.
- (b) Changeover valves may be comprised of a first- and second-stage regulator system in a single body or a combination of separate component items.

### 2.3 Regulators

- (a) Regulators and automatic changeover devices must comply with either:
  - (i). ASA621-2004
  - (ii). UL 144:2002
  - (iii). UL 252
  - (iv). BS EN 16129: 2013
  - (v). A relevant safe work instrument that specifies standards for LPG regulators or automatic changeover devices.
- (b) Only those regulators that are listed on WorkSafe New Zealand's register of gas fittings can be used.



- (c) Consideration must be given to the total expected gas load when sizing the regulator.
- (d) A single-stage regulator or the first stage of a multi-stage regulator, shall be located so that the length of the piping subject to cylinder pressure is as short as practicable.

## 2.4 Condensate trap

Condensate traps remove condensate and prevent transfer down stream of most condensates present in the LPG. A condensate trap should be installed between the first- and second-stage regulator if they are separate items. If the regulator is the combined type, then a condensate trap should be installed immediately after the regulator.

- (a) A condensate trap must have a vertical limb in a direct line to the first-stage regulator and be of a minimum volume of  $V=N \times 5.5$  where:  $V$  = The volume of the vertical limb in milliliters (ml)  
 $N$  = The number of 45 kg cylinders.
- (b) The trap must have a plug or other means of removing the condensate.

Examples of length of condensate trap tube for 10 and 13 mm pipe and various numbers of cylinders

Number of 45 kg cylinders	Length 10 mm pipe	Length 13 mm pipe
Two	140 mm	88 mm
Four	280 mm	180 mm
Six	370 mm	240 mm
Eight	560 mm	350 mm

## 2.5 Non-return valves

Where the regulator does not prevent LPG flowing across the changeover system, a non-return valve shall be fitted either in each pigtail connection of the changeover valve or as part of each pigtail.

## 2.6 Excess flow valves

For flexible pigtails manufactured to AS/NZS 1869 an appropriately sized excess flow valve must be fitted immediately after the outlet of each cylinder valve. The excess flow valve can be an integral part of the pigtail assembly.

## Section 3: Location of Cylinders

### 3.1 General

Cylinders and associated equipment should not be installed indoors unless specifically permitted in table 10 of schedule 12 of the HSW HS Regulations.

### 3.2 Prohibited locations

#### Clause 4.4.3 of AS/NZS 1596

Any *cylinder* and its associated equipment should not be installed in any of the following locations:

- (a) Within a building, except where permitted under table 10 of schedule 12 of the HSW HS Regulations
- (b) Under a stairway
- (c) In a location with restricted access where inspection, refilling or exchange of the *cylinder* is restricted, obscured or hazardous to the operator
- (d) Where nearby constructions, fences, walls or *vapour barriers* could prevent cross ventilation
- (e) Under a building, except where permitted by this Code
- (f) Where the *cylinder*, or an incident involving the *cylinder* and its contents, could obstruct egress from a building
- (g) Buried in the ground, unless the *cylinder* and *gas* installation have been specifically designed for such a location.

Any *cylinder* and its associated equipment should not be installed where damage is likely to occur, unless adequate protection is provided.

### 3.3 Cylinders on a verandah

#### Clause 4.4.7 of AS/NZS 1597

Where *cylinders* are located on a verandah, the following recommendations apply:

- (a) The location should be nominally at ground level
- (b) The verandah should be open on all three sides
- (c) The hazardous area around the *cylinders* should be free of fixed *ignition sources*
- (d) The *cylinders* should not be subject to physical damage, heat or vibration
- (e) A maximum of 90 kg should be kept on a verandah.

### 3.4 Cylinders in an enclosure or recess

#### Clause 4.4.10 of AS/NZS 1596

Where a *cylinder* is to be installed in an *enclosure* or recess, the *enclosure* or recess should be designed to:

- (a) house *cylinders* and their associated equipment only;
- (b) allow free unimpeded discharge from each *cylinder* safety valve;
- (c) ensure that water will not accumulate on the base; and
- (d) ensure the *cylinder* and its associated equipment are clear of the surrounding soil.

*Enclosures* of sheet metal or similar impervious construction should have ventilation openings at the top and bottom, with each opening providing a free area of at least 20 000 mm<sup>2</sup> for every *cylinder* enclosed.

### 3.5 Cylinders under buildings

#### Clause 2.2.8 of AS/NZS 1596

Where a *cylinder* is located under a building supported by piers, the following recommendations apply:

- (a) There should be a vertical clearance of at least 800 mm between the top of the neck ring of the *cylinder* and the underside of any overhanging part of the building
- (b) No part of the *cylinder* should be more than 800 mm within the perimeter of the building's walls
- (c) The area between the piers should be:
  - (i) open on at least three sides; or
  - (ii) enclosed by a construction through which cross ventilation can occur (eg, slats or battens) on at least three sides; or
  - (iii) a combination of Items (i) and (ii) above.

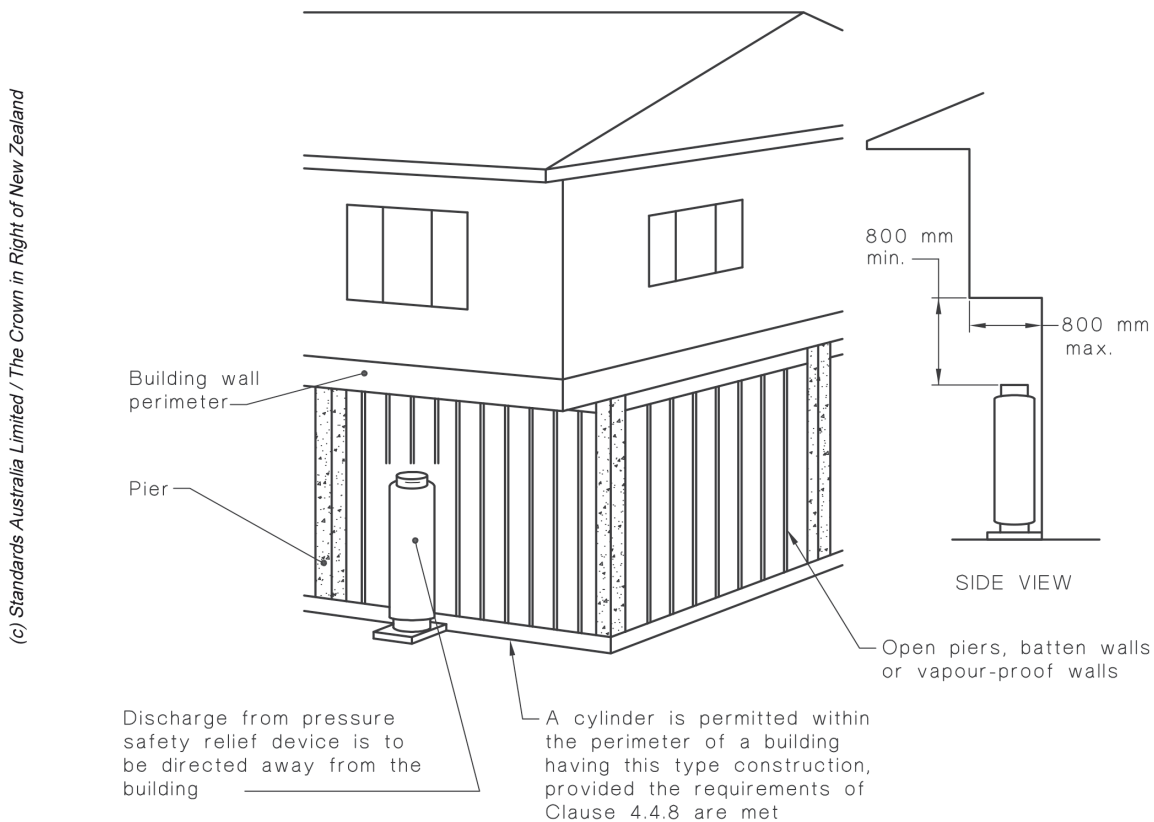

FIGURE 4.5 LOCATION OF CYLINDER UNDER A BUILDING

### 3.6 Requirements for cylinder location

Cylinder installations should be located such that the delivery of gas can be made safely by one person without excessive manual handling or risk to a customer's property. In situations where the following conditions cannot be satisfied, other options, such as locating the cylinders remotely and piping to the installation, should be considered.

- (a) Cylinder installation must be designed to be capable of accommodating the size of cylinder intended for use, for either exchange or insitu fill applications.
- (b) A minimum distance of 600 mm should be provided between the front of the cylinder installation and other structures to allow adequate access for the cylinder delivery to be made.
- (c) The cylinder compound should be accessible by cylinder trolley.
- (d) Paths should have a minimum width of 600 mm.
- (e) Steps should have a minimum of 2: 1 tread depth to tread rise. Maximum tread rise should be 125 mm.
- (f) Steps should not exceed 1.5 m total rise.

- (g) Paths should not exceed 20-degree gradients.
- (h) Total distance from cylinder delivery truck parking area and cylinder installation should not exceed 75 m.
- (i) It must be possible to legally and safely park the truck while making the delivery.
- (j) Access route should be firm and compact with adequate grip even in wet conditions.
- (k) The access route should not be over delicate or decorative surfaces, such as terracotta.

## Section 4: Cylinder Installation

### 4.1 Installing cylinders

#### From clause 4.4.11 of AS/NZS 1596

*Cylinders* should be installed in accordance with the following recommendations:

- (a) *Cylinders* should be installed on a firm, level, non-combustible base and not resting on soil. The floor or base should be constructed so that water cannot accumulate within any *enclosure* or recess
- (b) *Cylinders* should not be stacked on top of each other
- (c) Any *cylinder* that is liable to accidental dislodgment should be prevented from falling
- (d) Any *cylinder* larger than 25 litres and less than 200 litres water capacity shall be restrained against seismic activity
- (e) Except for domestic installations, where there are maneuvering vehicles, *cylinders* should be afforded suitable protection, eg, by the use of bollards, or a fully contained, free-moving frame which encapsulates all *cylinder* components
- (f) *Cylinders* should not be installed below ground level unless there is sufficient ventilation to prevent the accumulation of any leaking *gas*
- (g) A *cylinder* intended to be exchanged or removable should be connected to a fixed piping system
- (h) Vapour-service *cylinders* should be installed so that the point of *LPG* withdrawal is in contact with the vapour space
- (i) Where two or more *exchange cylinders* are connected for use, a means should be provided to permit the *cylinders* to be isolated from the *gas* supply, to allow the *cylinders* to be disconnected. This should be achieved by either of the following:
  - (i) a manual or automatic changeover valve should be installed immediately upstream of the regulator serving the system; and

**Note:** Such a valve may be an integral part of an *automatic changeover regulator*.

- (ii) *isolation valves* should be installed on the manifold, to allow each *cylinder* to be individually disconnected from the manifold without depressurizing the manifold.

## 4.2 Clearances around cylinders

Separation distances for LPG cylinders shall comply with the relevant HS Regulations and:

- Up to 100 kg can be installed within one metre of a building (up against the wall) provided there are no openings in the building below the top of the cylinders and within one metre of the cylinders.
- Cylinders should not be located within 1 metre of an opening to a drain, this is to prevent any gas leakage from entering the drain. Where a drain has a water seal or is sealed over, the 1 metre distance does not apply.
- Where the cylinders are located within 1 metre of a building, there must be no openings into the building below the top of any cylinder or within 1 metre of any cylinder. NOTE: Weep holes are not considered openings into the building for the purposes of this Clause.
- Where a cylinder is installed beneath a window, the distance between the top of any cylinder valve and the bottom of the window's opening shall be at least 150 mm for exchange cylinders and 500 mm for on-site filled cylinders.
- Between 100 to 300 kg can be installed within 2 metres of a building (up against the wall) provided the walls of the building behind the cylinders and 2 metres either side of the cylinders are vapour tight and constructed of fire-resisting material. There must be no openings in the building below the top of the cylinders or within two metres from the sides of the cylinders.
- There is a minimum vertical clearance from openings into buildings of 150 mm above the top of any cylinder. This clearance increases to 500 mm for in-situ filled cylinders.

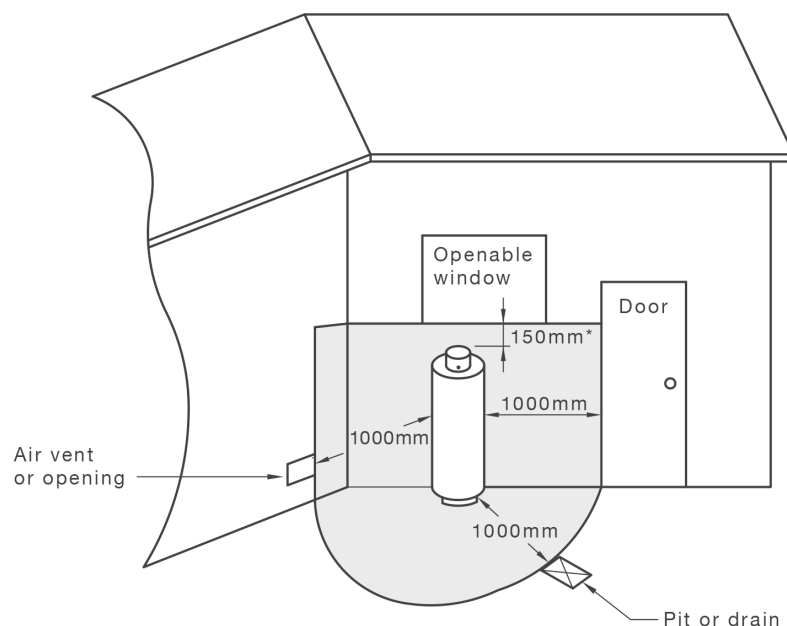

\* This distance is measured from the top of any cylinder valve

NOTE: In New Zealand, if the quantity of LP Gas totals 100 kg or more, the separation distance to openings into buildings increases to 2 m.

FIGURE 4.2 EXCHANGE CYLINDER LOCATION

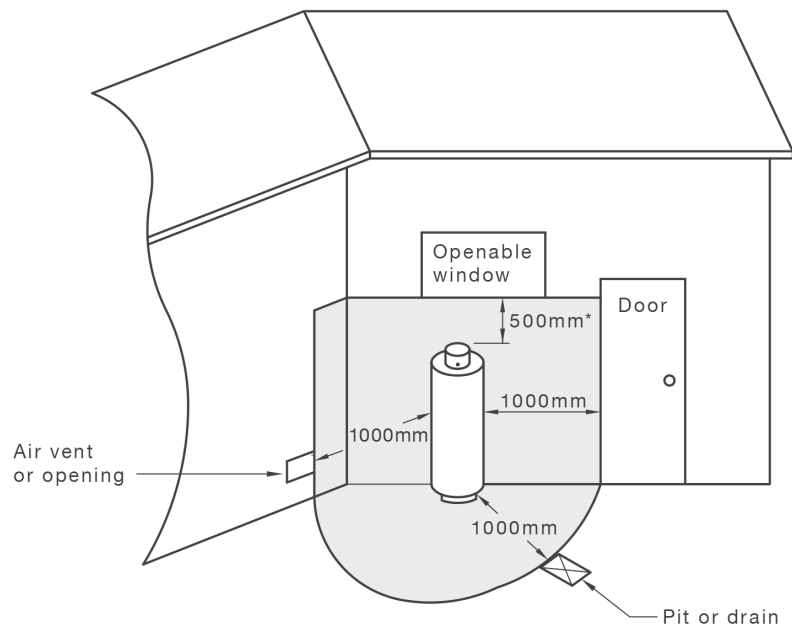

\* This distance is measured from the top of any cylinder valve

NOTE: In New Zealand, if the quantity of LP Gas totals 100 kg or more, the separation distance to openings into buildings increases to 2 m.

FIGURE 4.3 IN SITU FILL CYLINDER LOCATION

### 4.3 Cylinder safety valve discharge

A cylinder should be installed so that the pressure-relief valve is in contact with the vapour space and, where practicable, any discharge from this valve is directed away from any adjacent cylinders or combustible structures.

### 4.4 Regulators

#### From Clause 4.3.1 and 4.3.2 of AS/NZS 1596

Regulators shall comply with the following requirements:

- (a) The cylinder regulator shall be fixed rigidly to an adequate support that is independent of the cylinder and mounted with the diaphragm vertical and the vent pointing vertically downwards
- (b) Gas pressure regulators shall be located to permit drainage of any liquid back into the cylinder
- (c) Any first-stage regulator shall be outdoors, except where the regulator is attached to a cylinder that is permitted to be used indoors.
- (d) Second stage regulators shall be installed in accordance with AS/NZS 5601.1.
- (e) A single-stage regulator or the first stage of a multi-stage regulator, shall be located so that the length of the piping that is subject to cylinder pressure is as short as practicable



- (f) The outdoor discharge from a vent terminal, gas-pressure-relief device or terminal of a vent line shall be:
  - (i) arranged to minimise the risk of vapour collecting in drains, gutters and downpipes;
  - (ii) not less than 0.5 m in any direction from any opening into a building; and
  - (iii) not less than 0.5 m below and 1 m laterally from any fixed source of ignition.
- (g) The vent terminal shall have provision to exclude rain and insects.

## 4.5 Piping

### Clause 4.3.3 of AS/NZS 1596

The following requirements apply to the piping in a cylinder installation:

- (a) The piping between a cylinder and a manifold or a first-stage regulator shall be either of the following:
  - (i) Annealed copper tube:
    - (A) complying with AS 1572;
    - (B) having an alloy designation of 122 in accordance with AS 2738; and
    - (C) with a minimum wall thickness of 1.22 mm and a nominal size of 6 mm or 9 mm in industrial or commercial applications.
  - (ii) A flexible pigtail:
    - (A) complying with AS/NZS 1869 2012 Class F. Note: it is important to make sure it is a class F hose to AS/NZS 1869 2012, as this contains a significantly lower amount of phthalates than the other class of hoses and is the one specified for use as an LPG pigtail;
    - (B) having a maximum length of 600 mm;
    - (C) having a nominal size of 6 mm or 9 mm in industrial or commercial applications; and
    - (D) for a non-metallic lined flexible pigtail, having a maximum life of 6 years from the date of manufacture.
- (b) The piping as specified in Items (a)(i) and (a)(ii) shall be as short as practicable and not more than 1 m in length
- (c) The cylinder and piping shall be installed such that any liquid formed in the piping will drain freely back into the cylinder. Any such liquid shall not be allowed to drain back to the regulator.

## 4.6 Meters

- (a). Meters shall be installed in readily accessible locations where they are protected from damage, and that permit ease of replacement, maintenance and reading, and shall be clearly identified with the gas installation they supply.
- (b). Possible causes of damage include impact, corrosion, thermal extremes, excessive vibration, steam and dampness.
- (c). A recess or box in a cavity wall for housing a meter shall be:
  - (i). constructed of non-combustible material;
  - (ii). completely sealed from any adjoining recess or cavity;
  - (iii). adequately sized to permit ease of replacement or maintenance of the meter; and
  - (iv). ventilated to the outside atmosphere.

## 4.7 Hazardous area requirements

### Clause 4.4.6 of AS/NZS 1596

The hazardous zone surrounding a gas cylinder, as specified in AS/NZS 60079.10.1, shall be maintained free of ignition sources, this includes heat pumps, earthing rods and any communication wiring.

For exchange cylinders there is a zone 2 area within the space 0.5 m above and 0.5 m laterally from any cylinder valve, extending to a distance of 1.5 m laterally at the base of the cylinder.

For on-site filled cylinders there is a zone 2 area within the space 0.5 m above and 1.5 m laterally from any cylinder valve, extending to a distance of 3.5 m laterally at the base of the cylinder.

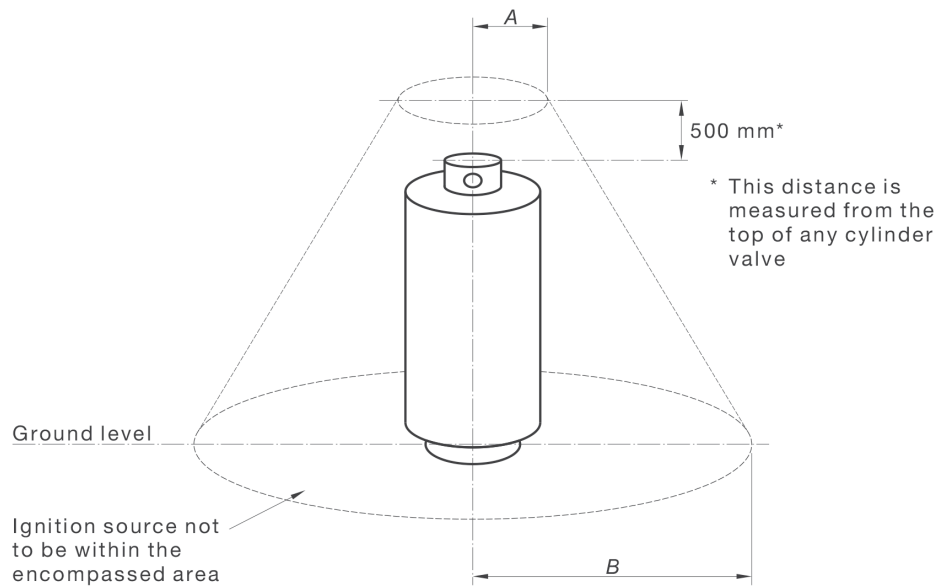

Radius	Exchange cylinder mm	In-situ fill cylinder mm
A	500	1500
B	1500	3500

FIGURE J3 MINIMUM CLEARANCE TO IGNITION SOURCES

## 4.8 Test points

Sufficient test points must be provided to carry out the following tests on the installation:

- (a) A pipework test on the newly installed pipework before any gas appliances are connected
- (b) An installation test, including all gas appliances, prior to connection of the gas supply
- (c) A final connection test.

## Section 5: Maintenance LPG Cylinder Installations up to 100 kg

### 5.1 Cylinders

Cylinders should not be filled unless they have been tested and certified within the last ten years.

### 5.2 Flexible pigtails manufactured to AS/NZS 1869

- (a) Pigtails should be inspected visually for cracks and deterioration every time the cylinder is exchanged or filled.
- (b) Pigtail connections should be checked with a soapy solution every time the cylinder is exchanged or filled.
- (c) Pigtails should be replaced six years from the date of manufacture.

### 5.3 Changeover valves

Changeover valves should be checked for correct operation in accordance with manufacturers recommendations or in the absence of any recommendation, at least every ten years.

### 5.4 First-stage regulators

- (a) The first-stage regulator to be checked for correct operation in accordance with the manufacturer's recommendations or in the absence of any recommendation at least every ten years.
- (b) The condensate trap to be drained by removing the drain plug provided at intervals not exceeding two years and at every visit of the gas fitter.

### 5.5 Second-stage regulators

The second-stage regulator to be checked for correct operation in accordance with the manufacturer's recommendations or in the absence of any recommendations, at least every ten years. The rubber diaphragm and rubber seal must be inspected for deterioration and replaced if necessary.

### 5.6 Condensate traps

Condensate traps should be emptied whenever any work is carried out on the installation and at least every 2 years.

Note: For the quantities of residue expected in the condensate traps, between 2 to 3 ml maximum, use disposable gloves when emptying the residue into absorbent material. This absorbent material and the gloves can then be disposed of in general waste.